

Grand Slam

Owner's Manual

Second Edition, December 2002

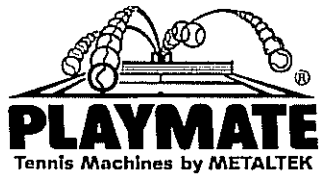

METALTEK

455 Kitty Hawk Drive
Morrisville, NC 27560

Tel: 919.544.0344

Fax: 919.544.1430

www.playmatetennismachines.com

Serial #: _____

Dear Valued Customer,

Congratulations on the purchase of your new Playmate Tennis Ball Machine; the best ball machine in the world! We have packed over 27 years of experience and dedication into the production of each and every ball machine to leave our new high tech facility in Morrisville, North Carolina. It has been our mission to create the most durable, dependable, and player-friendly machines possible, all the way from the gear motors and pitching wheels, to the fully programmable control boxes and remote controls. We hope that you enjoy our ball machines as much as we do, and encourage your comments and suggestions on how we could better serve you in the future. Please feel free to contact us on our Consumer Connection Line at 1-800-776-6770.

Sincerely,

Alfred F. Yarur
President and CEO

Contents

Introduction	4
Safety Instructions	5
Electrical Requirements	6
Getting Started	7
Operating Instructions	9
Getting to Know Your Grand Slam	14
7 Favorite Shots	15
Drill #1	16
Drill #2	17
Care and Maintenance	19
Troubleshooting	20
Playmate Consumer Connection	21
Warranty and Limitations of Liability	22

Introduction

The best way to improve your tennis game is to practice. That may sound like simple advice, but it's advice we take very seriously here at METALTEK. We believe that the best way to practice your game is to spend some quality time on the court with a ball machine. Only by utilizing a ball machine as a constant partner will you be able to repeatedly attack all the shots that make up your range as a player, whether that means strengthening your weaknesses or perfecting your strengths. A ball machine is your best choice or practice partner when it comes to developing a well-rounded game.

In this age of technological development, we have tried to find a happy balance between technical complexity and ease of operation. We have worked hard to maintain the clean simple appearance of our design and the utility of our controls, while generating machines that can offer full game simulation and programmability. Even if you are still having trouble programming the VCR, we hope that our machines will present themselves without difficulty. After only a short while with this manual you should be able to have your new Playmate up and running and be practicing the shots that you want to be practicing!

Safety Instructions

WARNING! To reduce the risk of electrical shock, fire, injury to persons, and other damage when using this product, please follow these basic safety precautions.

1. Read all instructions carefully before operating this machine.
2. To protect against the risk of electrical shock, never immerse any part of this machine in water or any other liquid.
3. Always use a grounded three-prong extension cord to supply power to this ball machine.
4. Close supervision is necessary when operating this machine near children.
5. Never walk in front of this machine when it is operating. Tennis balls leave the machine at high speeds and could cause serious injury.
6. Always stand to the side, or behind the machine when attempting to alter the settings of the various controls.
- 7. If it is necessary to free a jammed tennis ball, make sure that the machine is turned OFF and unplugged.**
8. Always wear protective eyewear when attempting any repairs or adjustments on this machine.
- 9. Never attempt any repairs or adjustment on this machine when it is plugged in. Always turn the power switch OFF and unplug the power cord.**
- 10. This machine is intended for pitching tennis balls only. Never attempt to use this machine with any other type of ball, or any foreign objects whatsoever.**
11. Always make sure to turn this machine OFF when it is not in use.

Electrical Requirements

A heavy-duty power cord (not included) is recommended for use with the Playmate Ball Machine. All machines should be plugged into a 120V 50/60 Hz outlet (220V 50/60 Hz outlet for overseas machines equipped with transformers). If you are using an extension cord of 100 feet long or less, we recommend that you use a 16 gauge or heavier extension cord that is grounded. For longer distances, a 14 gauge grounded extension cord is recommended.

Getting Started

Your new Playmate should have arrived securely packed. Make sure to inspect the machine for any damages that could have occurred during shipment. If machine is damaged please save all packing and box for inspection purposes. Inside the packing box, you should have found the owner's manual, warranty card, and hand held remote control. If any of these are missing, please notify Metaltek immediately. Your new Playmate should be ready for use in only a few minutes by completing the following easy steps.

- 1. ASSEMBLING THE HANDLES** – The handles are reversed along the sides of the machine for compact shipment. To place them in their proper position, loosen the black triangular head screws until they are free. Swing the handles around 180 degrees until they are running parallel to each other behind the machine. Line up the holes and replace the triangular head screws, tightening until snug. **DO NOT OVERTIGHTEN.**
- 2. SUPPLYING POWER** – Plug an extension cord into a grounded three-prong outlet of the proper ratings (see **ELECTRICAL REQUIREMENTS** page 6), and attach the other end to the power cord on the right side of the machine.
- 3. FILL THE HOPPER** – Depending on whether your machine has a large or small hopper, it will hold anywhere from 200 to 300 tennis balls. We recommend using pressureless tennis balls because they respond better for a longer period of time. Pressureless tennis balls are available from Metaltek by the gross.
- 4. SET THE CONTROLS** – Your machine is just about ready for use. The last thing you will need to do is set the controls to a specific program. Make sure to carefully read the **OPERATING INSTRUCTIONS** before attempting to use this machine.

NOTE: If possible, save the shipping box that your Playmate arrived in. Not only will it provide a safe place for long term storage, but will also provide proper protection if it is ever necessary to ship your Playmate in the future.

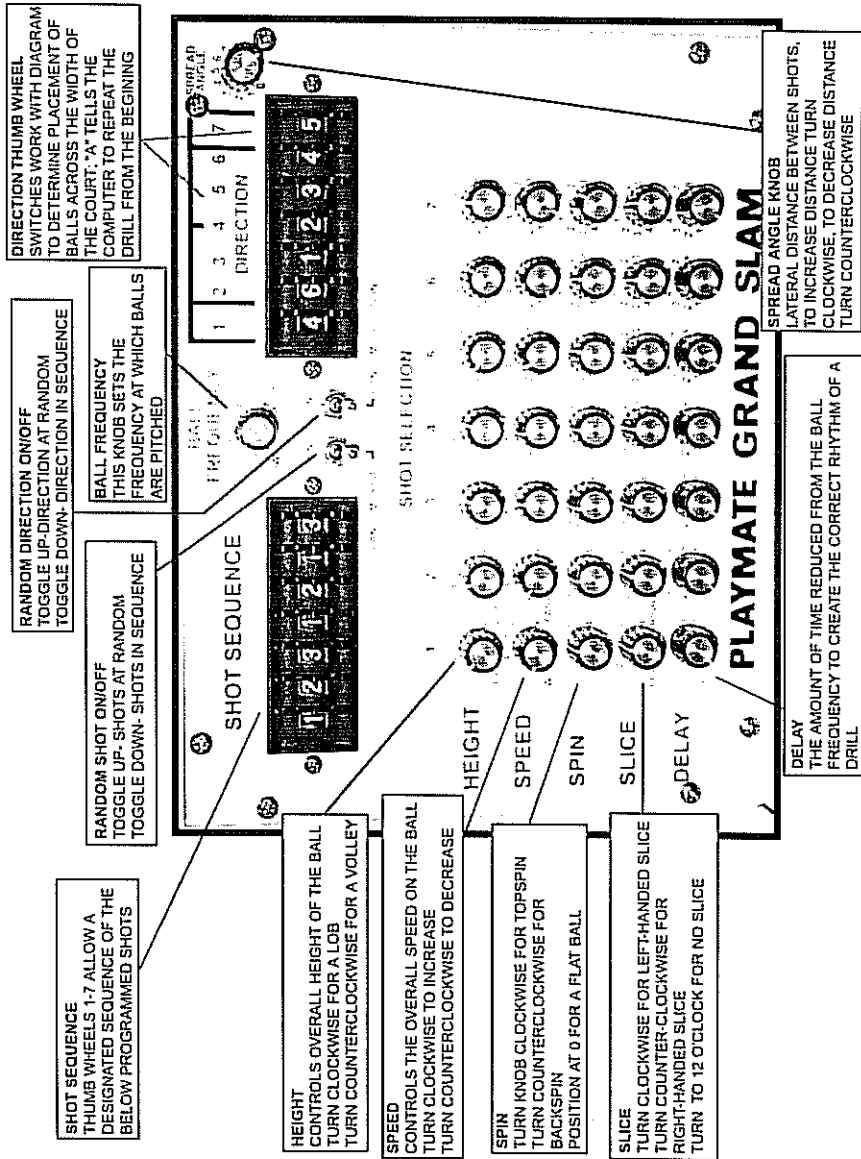

Operating Instructions

The control box on the **Grand Slam** is located on the back of the ball machine hopper.

- 1. POWER-** This switch controls the power to the machine. When it is illuminated, power is being supplied.
- 2. BALL FREQUENCY** – This knob determines the frequency at which the balls are pitched. Turning the knob clockwise increases the number of balls pitched to a maximum of approximately one ball per second. Turning the knob counterclockwise decreases the number of balls per minute.
- 3. REMOTE** – This machine is equipped with a radio remote control system. By selecting the ON position of the REMOTE toggle switch, the hand held remote becomes activated. By selecting the OFF position of the REMOTE toggle switch, the hand held remote becomes deactivated.
Note: If the REMOTE toggle switch is in the off position then the machine will begin to project the balls.

SHOT SEQUENCE AND DIRECTION CONTROLS

The SHOT SEQUENCE and DIRECTION controls work together to program the direction and which shot leaves the ball machine. The DIRECTION control determines the horizontal placement of the ball across the width of the tennis court. The SHOT SEQUENCE control allows you to select shots from the SHOT SELECTION MEMORY and place them in the order in which they are to be thrown. Using these controls in combination, the machine can be programmed to do everything from pitch the same exact shot repeatedly, to produce infinite variations and game like conditions.

- 4. SHOT SEQUENCE** – This control features seven thumb wheels. Each thumb wheel is numbered "1" through "7", with thumb wheels "2" through "7" having an extra letter "A" after the last number. Once the letter 'A' is selected, it will limit the shots to those set to the left of it. These thumb wheels correspond to the shots programmed using the SHOT SELECTION MEMORY control panel located directly below the main control panel. All seven different programmed shots can be selected, or any combination of them.

- 5. SHOT SELECTION – MEMORY** – The shot selection panel features seven shot selection memories, each utilizing five different control knobs. These knobs can be used to set the HEIGHT, SPEED, SPIN, SLICE and DELAY of each shot.

HEIGHT: This knob controls the overall height of the ball being pitched. Turning this knob to the right increases the height of the ball. Turning it to the left decreases it.

SPEED: This knob controls the speed of the ball being pitched. Turning this knob clockwise will increase the speed of the ball being pitched, turning it counterclockwise will decrease it.

SPIN: This knob controls the TOP and BACKSPIN of the ball being pitched. Turning this knob clockwise will give TOPSPIN, counterclockwise BACKSPIN, if this knob is at 12 o'clock it will be a flat ball.

SLICE: This knob controls the amount of slice applied to the ball being pitched. Turning this knob clockwise will put a left-handed slice on the ball; counterclockwise will put a right-handed slice on the ball. If this knob is at 12 o'clock there will be no slice.

DELAY: This knob allows you time to return to the baseline or create the appropriate intervals between shots during a drill. The delayed shot should only be used once in a drill to achieve correct drill rhythm.

Note: For an example of the various SHOT SELECTION controls, please see the section entitled "GETTING TO KNOW YOUR GRAND SLAM".

- 6. SHOT SEQUENCE – RANDOM ON/OFF** – Once all the shot selection memories have been programmed and the shot sequence thumb wheels have been set, the order in which they are pitched by the ball machine can be selected with the RANDOM ON/OFF mode toggle switch. If this toggle switch is placed on RANDOM OFF, the shots will be pitched in the exact order in which they have been selected on the SHOT SEQUENCE thumb wheels. If the RANDOM ON mode is selected, the machine will produce the selected shots in a completely random order, automatically producing up to 800,000 possible combinations. To increase the probability of a specific shot, set at least two of the shot selection memory controls to that shot. To triple the probability, set at least three of the shot selection memory controls to that shot.

- 7. DIRECTION PROGRAM - RANDOM ON/OFF** – The DIRECTION control features seven built-in directions. The seven numbers across a base line graphically represent the direction of each of the shots from left to right on a standard double's court. There are seven thumb wheels, labeled "1" through "7" which recall the seven specific directions in any order, producing different patterns. Each thumb wheel switch features any of the seven directions for your selection. To set a pattern of shots, turn each of the thumb wheel switches up or down to the number of the corresponding directions you desire. Thumb wheel switches "2" through "7" feature the extra letter 'A'. If this letter is selected, it will limit the shots to those set to the left of it. If the RANDOM ON mode is selected, the machine will produce the selected directions in a completely random order, automatically producing up to 800,000 possible combinations. To increase the probability of a specific direction, set at least two of the direction thumbwheels to that direction, and to triple the probability, set at least three of the direction thumbwheels to that direction.

Example: To select a left and right shot only, set the first thumb wheel switch on the left to 3. Then set the second thumb wheel switch to shot 5. Then select the letter 'A' on the third thumb wheel switch in order to limit the sequence to 3 and 5.

- 8. SPREAD ANGLE** – The lateral distance, or SPREAD ANGLE, between the seven different shots can be adjusted with the SPREAD ANGLE knob. In order to increase the lateral distance between the shots, turn the SPREAD ANGLE knob clockwise. To decrease the lateral distance between shots, turn the SPREAD ANGLE knob counterclockwise. Direction "4" will always remain at the center position while the others change accordingly. The difference between the maximum and minimum spread angle is approximately 50 percent.

OTHER CONTROLS

RADIO REMOTE CONTROL – The hand held remote control unit activates and deactivates the ball delivery system of the Playmate tennis machine. Push the button once to activate the delivery system, and once more to deactivate it. On ACE GENIE series or any directional machines if you hold the button down for 3 seconds it will reset the machine. The remote control is only active when the POWER switch is illuminated, and the REMOTE toggle switch is in the ON position. The radio antenna is located in the back of the ball hopper. Make sure this antenna is pointing upward in order to increase the range of

the remote control system.

SAFETY PRECAUTION: If the machine is turned ON and the REMOTE ON/OFF switch is in the OFF position the machine will begin to pitch balls.

NOTE: Any control adjustments can be made while the machine is running, provided the safety precautions are being followed.

This Page Was Intentionally Left Blank

Getting to Know Your Grand Slam

If you have never used a Playmate Tennis Ball Machine, or are unfamiliar with the programmable possibilities of the GRAND SLAM, please take a moment to follow these few easy steps to better comprehend the features of your new ball machine.

1. Place the machine at the center of the base line.
2. Check to make sure that the machine is plugged into a electrical outlet of the proper specifications (120 V AC 50/60 Hz, or 230 V AC 50/60 Hz for overseas machines equipped with transformers).
3. Load the hopper with tennis balls, making sure to stay clear of the ball exit in the front of the machine.
4. Now program the SHOT SELECTION MEMORY in accordance with the GENIE V SET-UP located on the next page.
5. Go to the back of this manual and follow directions to **DRILL #1**. It will throw a Flat Groundstroke or Volley to your Forehand/Backhand.
6. Now move on to **DRILL #2** which will allow you to incorporate the DELAY feature, allowing you to return to the baseline following a short ball.

Grand Slam Set-Up

7 Favorite Shots

Developped by Stan Oley

Shot	Flat Groundstroke or Volley	Moonball or Offensive Lob	High Approach Shot	Low Approach Shot or Half Volley	High Lob or Defensive Lob	Topspin Groundstroke or Volley	Backspin Groundstroke or Volley
Height	3	7	6	4	10	4	3
Speed	6	5	4	5	4	5	5
Spin	0	0	0	0	0	4T	4B

T - topspin B - backspin

GRAND SLAM DRILL

Developed by Stan Oley

Drill #1

Flat Groundstroke or Volley to Forehand/Backhand

(based on shots found in Grand Slam Set-Up, page 17)

Set *Remote* switch to **ON**

Push *Red On/Off Switch* on Ball Machine to **ON**

Set *Random Direction* to **OFF**

Set *Random Sequence* to **OFF**

Set *Shot Sequence* first and second thumbwheels to **1,1,A**

Set *Direction* thumbwheels to **3, 5, A**

Set *Ball Frequency* to **40**

Now walk to the other side of the court and use your remote control to start your drill. When balls are depleted or you tire, turn machine feeder off with remote before loading balls.

As a variation, switch *Random Direction* to **ON** to receive forehand/backhand in *Random*.

TIP

REMEMBER TO PLACE THE MACHINE WHERE THE BALL WOULD COME FROM IN A MATCH, DOUBLES PLAYERS SHOULD PLACE MACHINE IN AD OR DEUCE COURT AND PLAY OPPOSITE OF MACHINE. GOOD LUCK!

GRAND SLAM DRILL

Developed by Stan Oley

Drill #2

**Flat Groundstroke followed by a High Approach Shot to Forehand/
Backhand**

(based on shots found in Genie V Set-Up, page 17)

Set *Remote* switch to ON

Push *Red On/Off Switch* on Ball Machine to ON

Set *Random Direction* to OFF

Set *Random Sequence* to OFF

Set *Shot Sequence* first and second thumbwheels to 1,3,A

Set *Direction* thumbwheels to 3, 5, A

Set *Delay* knob on *Shot Selection Memory* Shot #1 to 6

Set *Ball Frequency* to 40

Now walk to the other side of the court and use your remote control to start your drill. After hitting your approach the machine will ***Delay*** and allow you to return to the baseline. When balls are depleted or you tire, turn machine feeder off with remote before loading balls.

As a variation, switch ***Random Direction*** to **ON** to receive forehand/backhand in ***Random***, or reverse ***Direction*** to 5,3, A.

TIP

REMEMBER TO ALWAYS USE TARGETS WHEN TRAINING WITH THE BALL MACHINE. AN AREA OF FOUR 8" CONES IS GOOD. YOU SHOULD COMFORTABLY HIT YOUR TARGET AREA 70% OR THE TIME.

This Page Has Been Intentionally Blank

Care and Maintenance

With proper care and maintenance, your Playmate tennis ball machine should last for years and years of effortless operation. These few basic steps will help to keep your machine in great shape, and deter any future mechanical problems.

- 1. PERIODIC CLEANING** – Over a period of use, various debris, and ball fuzz will begin to build up on the interior of the ball machine cabinet. This should be cleared away periodically to avoid excessive build up that could clog mechanical parts. Use a damp cloth to wipe down both the interior and exterior surfaces of the machine. Very gently use a dull object to help break away large clumps of debris. Never scrape at the surface of your Playmate ball machine with a sharp object, or use any harsh abrasives or solvents. Loose debris can be vacuumed out of the ball machine cabinet. Never use a hose to attempt to spray debris out of the interior of the machine. Excessive water pressure can damage the sensitive electrical components, as well as increase the risk of electric shock.
- 2. PERIODIC LUBRICATION** - The majority of the moving parts inside the ball machine are lubricated and sealed at the factory. These parts should require no lubrication at all. In order to maintain the ease of operation however, periodic lubrication of the Oscillation and Elevation crank arm linkage is recommended. To do this, turn the machine upside down, resting the hopper on a piece of cardboard or other protected surface. Turn the Oscillation crank handle a few times while inspecting to see that the threaded linkage is free of debris and obstruction. Place a few dabs of lubrication (we recommend a white lithium grease) on both sides of the plastic seat and continue to rotate the Oscillation crank handle several times to assure the even distribution of the lubricant. Repeat with the Elevation linkage.

Troubleshooting

PROBLEM	POSSIBLE CAUSE	APPROPRIATE ACTION
Inconsistent ball speed	-Pitching wheels are heavily worn. The pitching surface has become dirty.	-Wheels need to be sanded and/or cleaned. Use medium grit sandpaper to restore the textured surface of the wheels.
Ball is not pitched	-Tennis balls and/or pitching wheels are wet. -A ball has jammed.	-Wheels and/or tennis balls require cleaning and drying. Remove any wet balls from the hopper. -Turn off power and remove any jammed balls.
Feeding disk does not turn	-Loose electrical connection. -There is a problem with the remote relay.	-Turn the machine upside down and check the connection of cord #3 at the side of the control box. -Turn the Remote ON/OFF switch to off. If the feeding disk works properly, check the remote. See remote troubleshooting below.
Balls repeatedly jam	-The ball feed wire is damaged or missing.	-Inspect the position of the feed wire over the feed disk. Make sure it allows only one ball to enter each slot in the feed disk as a time. If it is missing, call Metaltek for a replacement.
Remote does not function properly	-Antenna is not facing upward. -Battery is dead. -Remote ON/OFF switch on control panel is set to OFF	-Reposition antenna -Replace battery in hand held remote. -Set Remote switch to ON
Elevation and Oscillation handles do not turn easily	-Threaded linkage arms are clogged with debris, or lack proper lubrication.	-Clean debris from the threaded linkage arms and lubricate with a light coating of lithium grease.
Pitching motors and/or interval motor do not operate properly	-Loose electrical connection	-Turn machine upside down and check the connection of cords #1 and #2 at the side of the control box.

Playmate Consumer Connection

We are here during business hours to help provide technical assistance to our customers.

Hours of Operation: Monday - Friday
8:00am - 4:30pm (EST)

If you experience difficulty with your Metaltek Products please feel free to contact us at one of the following numbers.

Phone: (919) 544-0344
Toll Free (USA): 1-800-776-6770
Fax: (919) 544-1430

Or write us at:
METALTEK
455 Kitty Hawk Drive
Morrisville, NC 27560
USA

Or e-mail us at:
metaltek@msn.com

Authorized Sales & Service Center

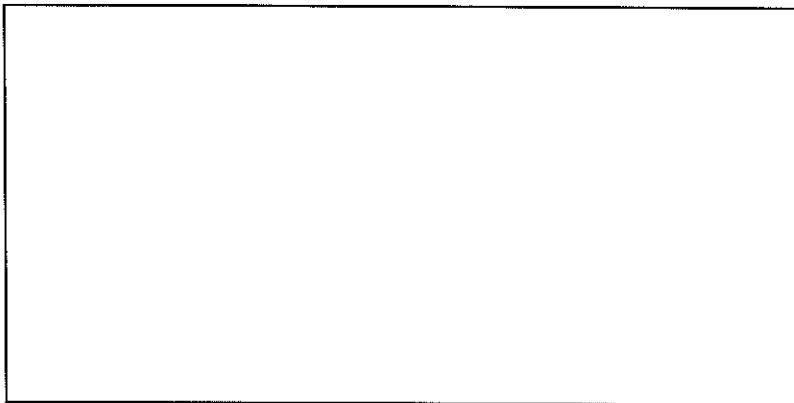

Warranty and Limitations of Liability

FULL THREE –YEAR WARRANTY - The PLAYMATE tennis machine is warranted against defects in materials and workmanship for three (3) years from the date of delivery. During the warranty period, METALTEK will repair or, at its option, replace at no charge components that prove to be defective, provided the parts are returned, shipping prepaid, to METALTEK.

This warranty does not apply to the normal wear and tear to the machine or its components as received from proper use.

Nor does this warranty apply to any damage to the machine or remote control, or to any other components caused by accident or misuse or as a result of service or modification by any persons other than those certified by METALTEK. No other express warranty is given by METALTEK.

METALTEK SHALL NOT BE LIABLE FOR CONSEQUENTIAL DAMAGES.

OBLIGATION TO MAKE CHANGES – Products are sold on the basis of specifications applicable at the time of sale. METALTEK shall have no obligation to modify or update products once sold.

METALTEK'S PLANT: **REPAIR POLICY**
 455 Kitty Hawk Drive
 Morrisville, NC 27560
 USA

REPAIR TIME – Parts are normally repaired and returned within five (5) working days of receipts at METALTEK'S plant.

SHIPPING INSTRUCTIONS – Parts should be returned in a protective package to avoid in-transit damage. Such damage is not covered by warranty.

SHIPPING CHARGES – Whether the machine is in warranty or out of warranty, the customer should prepay shipment to METALTEK.

FURTHER INFORMATION – Service contracts are not available. Machine control circuitry and design are proprietary to METALTEK and manuals are not available to customers. Should other problems or questions arise regarding repairs, please call METALTEK.